

P-Channel MOSFET Transistor

2SJ82 / J82

140V / 7A

DATASHEET

OEM – Hitachi

Source: Hitachi Databook Power Mosfet Data 4/83

2SJ81, 2SJ82, 2SJ83

SILICON P-CHANNEL MOS FET

LOW FREQUENCY POWER AMPLIFIER

Complementary Pair with 2SK225, K226, K227

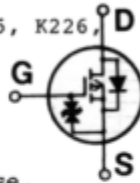

Features;

- High Power Gain.
- Excellent Frequency Response.
- High Speed Switching.
- Wide Area of Safe Operation.
- Enhancement-Mode.
- Good Complementary Characteristics.
- Equipped with Gate Protection Diodes.

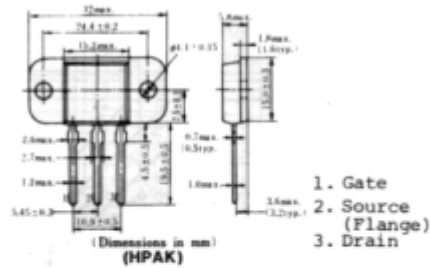

■ ABSOLUTE MAXIMUM RATINGS (Ta=25°C)

Item	Symbol	Rating			Unit
		J81	J82	J83	
Drain-Source Voltage	V _{DSX}	-120	-140	-160	V
Gate-Source Voltage	V _{GS}	±15			V
Drain Current	I _D	-7			A
Body-Drain Diode Reverse Drain Current	I _{DR}	-7			A
Channel Dissipation	P _{ch} *	100			W
Channel Temperature	T _{ch}	150			°C
Storage Temperature	T _{stg}	-45 ~ +150			°C

*Value at Tc=25°C

POWER VS. TEMPERATURE DERATING

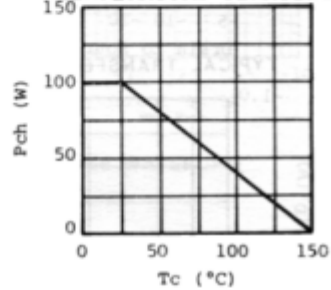

■ ELECTRICAL CHARACTERISTICS (Ta=25°C)

Item	Symbol	Test Condition	min.	typ.	max.	Unit
Drain-Source Breakdown Voltage	J81	I _D = -10mA, V _{GS} = 10V	-120	-	-	V
	J82		-140	-	-	V
	J83		-160	-	-	V
Gate-Source Breakdown Voltage	V _{(BR)GS}	I _G = ±100µA, V _{DS} = 0	±15	-	-	V
Gate-Source Cutoff Voltage	V _{GS(off)}	I _D = -100mA, V _{DS} = -10V	-0.15	-	-1.45	V
Drain-Source Saturation Voltage	V _{DS(sat)}	I _D = -7A, V _{GS} = 0*	-	-	-12	V
Forward Transfer Admittance	Y _{fs}	I _D = -3A, V _{DS} = -10V	0.7	1.0	1.4	S
Input Capacitance	C _{iss}	V _{GS} = 5V, V _{DS} = -10V, f = 1MHz	-	900	-	pF
Output Capacitance	C _{oss}		-	400	-	pF
Reverse Transfer Admittance	C _{rss}		-	40	-	pF
Turn-on Time	t _{on}	V _{DD} = -20V, I _D = -4A	-	230	-	ns
Turn-off Time	t _{off}		-	110	-	ns

*Pulse Test

2SJ81,2SJ82,2SJ83

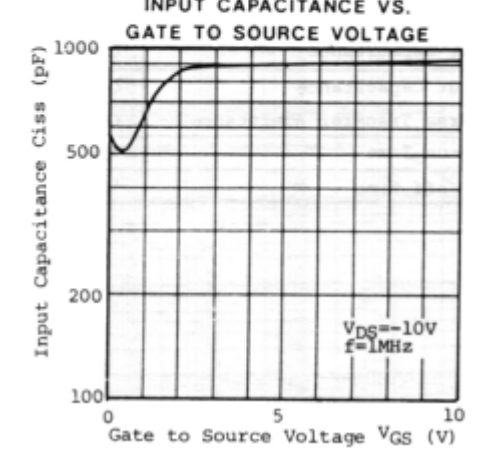
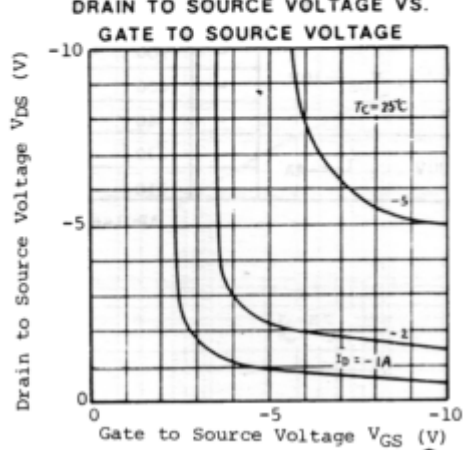
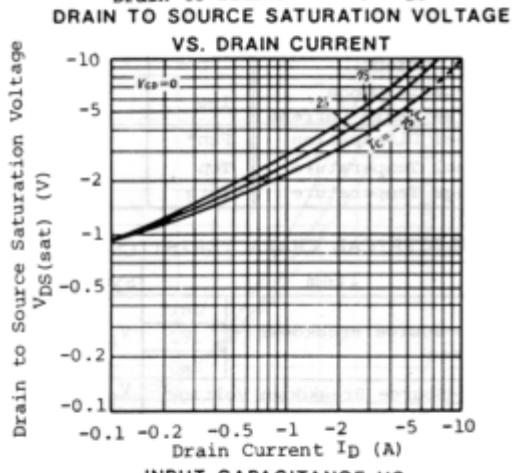
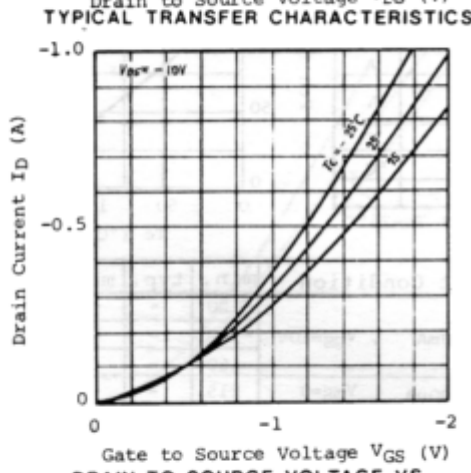
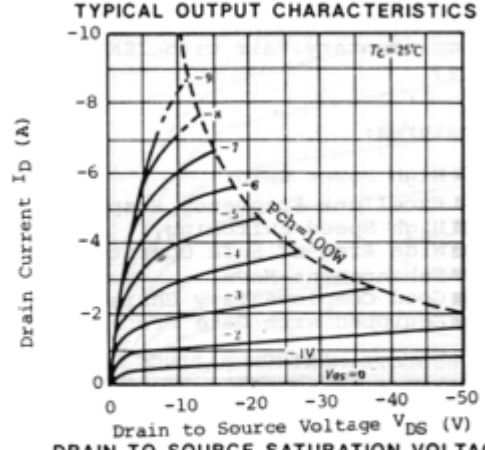
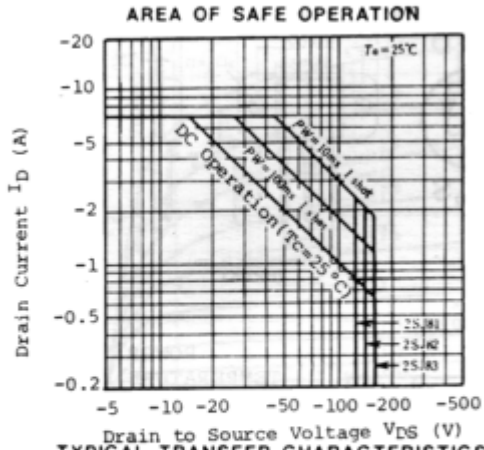

2SJ81,2SJ82,2SJ83

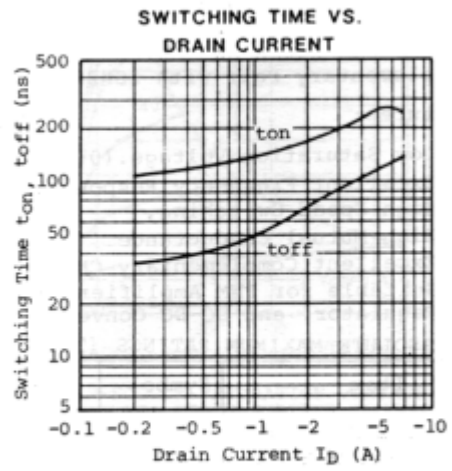
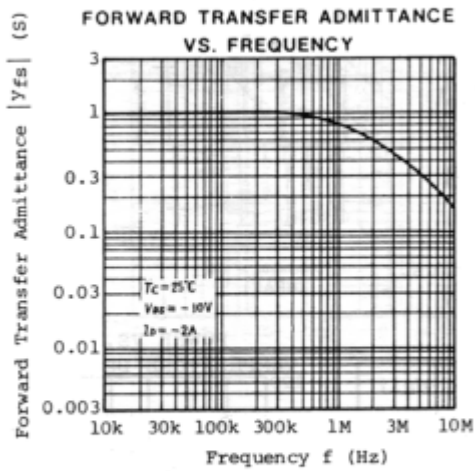

SWITCHING TIME TEST CIRCUIT

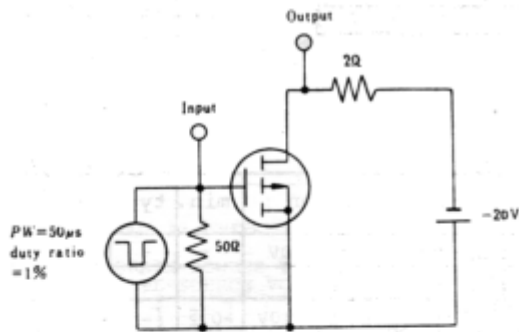

RESPONSE WAVEFORM

